

STANDARD FEATURES

- SilentSonic Technology
- Intuitive Touchscreen Controls
 - Visual Water Level Indicator
 - Auto-Fill
 - On-Board Service Diagnostics
 - Active Alerts
- Flatware Saver
- Flushing Valve to Pump-motor Seal
- Remote Mounted Control Box and Circuit Breaker
- Removable, Gasketless Water Extractor Door
- Start/stop Switch Mounted on Extractor
- Total Stainless Steel Construction
- Water Level Control
- Automated Wash Down Cycle
- Automatic Drain
- Flanged Feet with Anti-Vibration Dampening
- Recirculating Pump
- Deodorizer Injector
- Extractor Flushing System

Sonic 5 PRO

5 Hp - 24" Advanced Food Waste Reduction System



OPTIONS & ACCESSORIES

- Spray Reel - 6 ft (recommended if no other hose present), unmounted
- Remote mounted start-stop station (unmounted)
- Multiple trough configurations (9" & 12")
- "The Grabber" trough mounted magnet
- Remote Extraction System (Contact Factory)

SPECIFIER STATEMENT

Specified unit will be Bi-line model SONIC 5 PRO waste handling system. Features include a standard feed tray, total stainless steel, free-standing close coupled waste handling system with a 24" diameter slurry chamber, 5 Hp grinding motor and 2 Hp extractor motor. Three stationary blocks with four cutting surfaces each, two tool steel rotating shearing blades, large water extractor chamber with removable gasketless door, touchscreen operator controls, automated washdown function, and automatic drain.

1 year parts and labor warranty.

TROUGH FEED

Volume crated: **99 cu. ft.**
Shipping weight crated: **1000 lbs.**
Dimensions shown in inches

FRONT VIEW

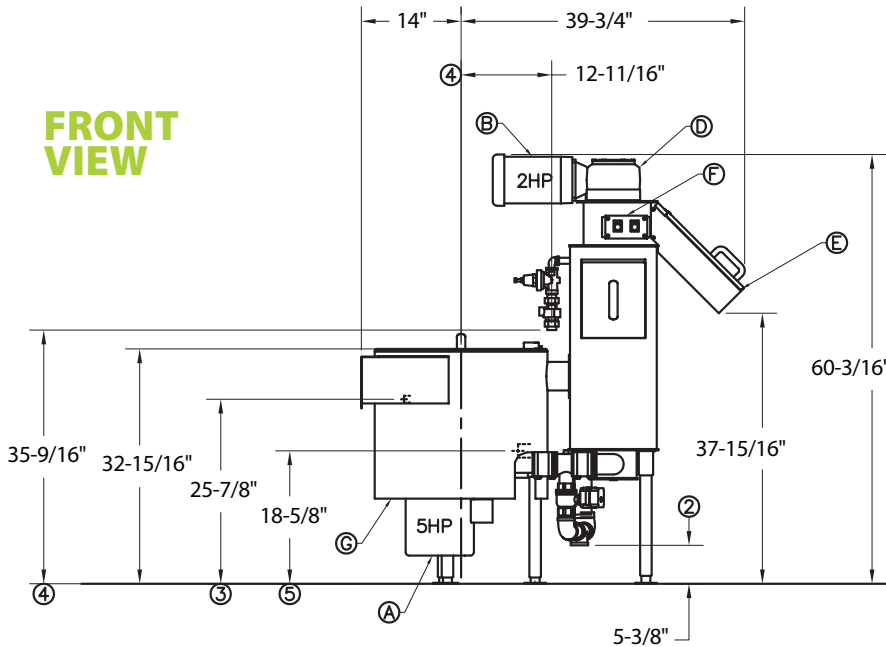

TOP VIEW

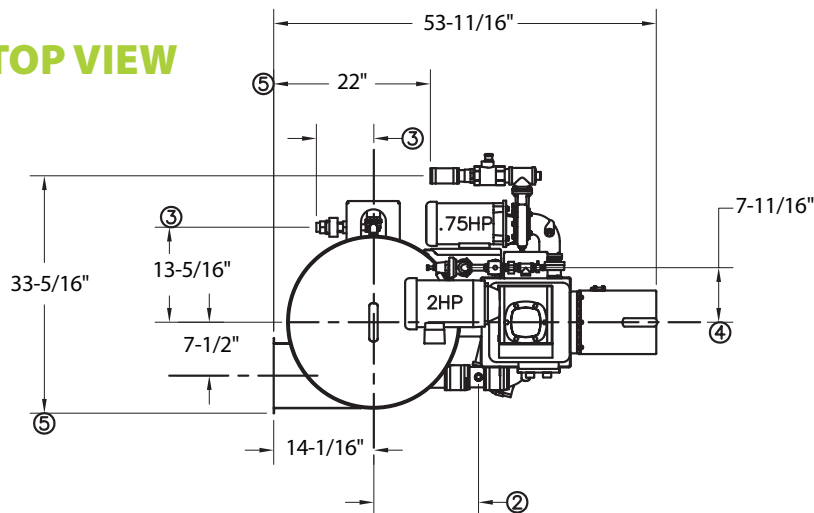

Utilities

1	Electrical See Chart page 3
2	Optional Recirculation Pump
3	Drain 1-1/2" NPT.
4	Cold Water 1/2" NPT cold water connection.

Item	Qty.	Description
A	1	Slurry Chamber 30" dia.
B	1	Motor – Main Drive 5 Hp
C	1	Water Extractor Drive Motor 2 Hp
D	1	Water Extractor
E	1	Discharge Chute
F	1	Scrapping Tray
G	1	Start/Stop Station

Warning: Plumbing and electrical connections should be made by qualified personnel who will observe all the applicable plumbing, sanitary and safety codes and the National Electrical Codes.

Note: Water Hammer Arrestor (meeting ASSE-1010 standard or equivalent) to be supplied (by others) in common water supply line at service connection.

SPECIFICATIONS

Capacities Input

Waste (approx. lbs. per hr.) 750

Water Consumption

Item gal
Item gal

Motor Horsepower

Pulper 5
Water Extractor 2
Recirculation Pump 3/4

Slurry Chamber

Tank (in. dia.) 30
Cutting Disk (in. dia.) 12

Connections

Fresh water (in.) 1/2
Drain (in.) 1-1/2

TRAY FEED

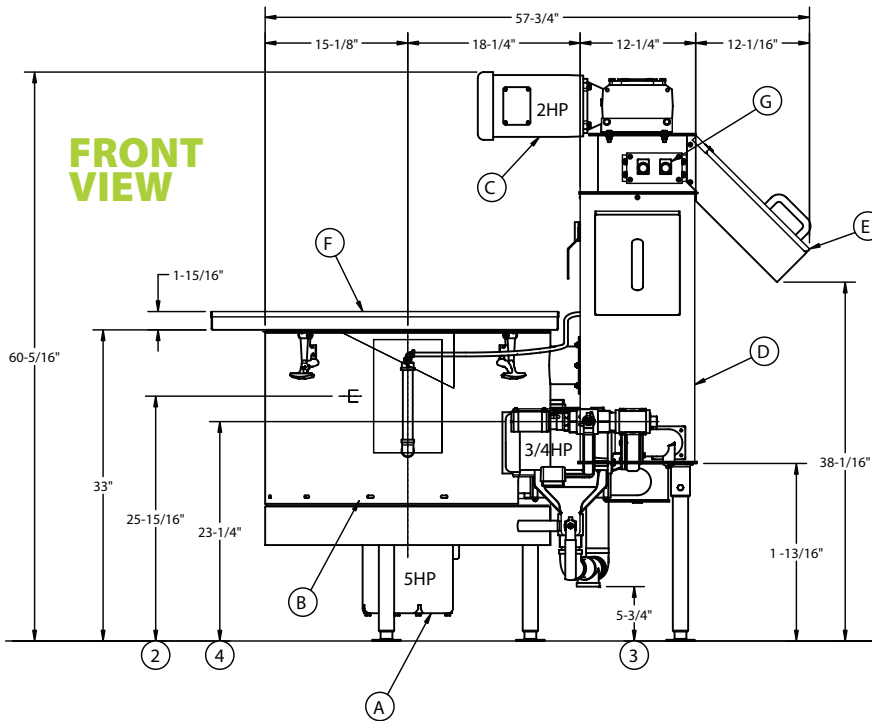

REMOTE MOUNTED CONTROL CABINET

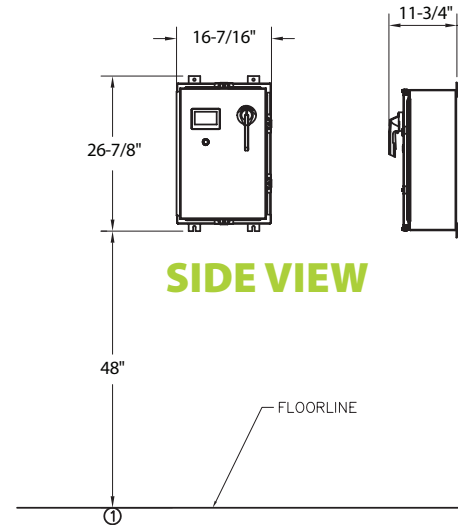

TOP VIEW

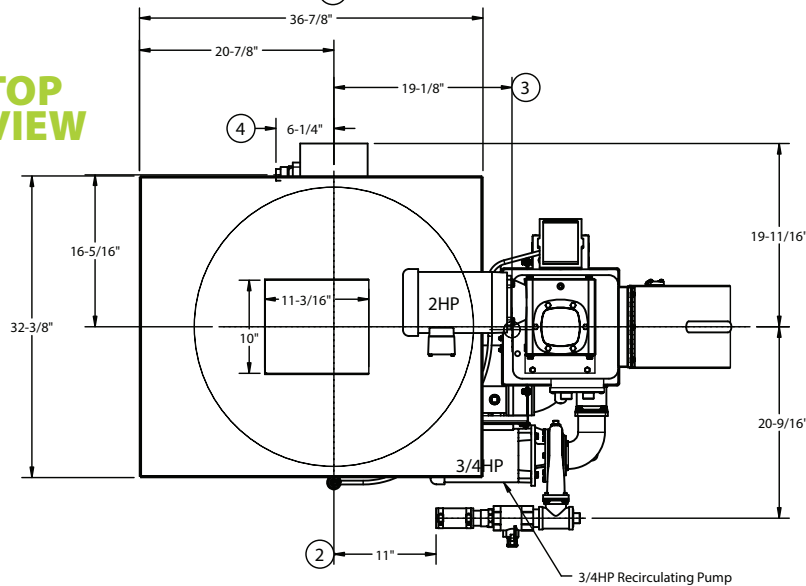

SONIC 5 PRO

Elec. Specs	Rated Amps	Minimum Supply Ckt. Conductor Ampacity	Maximum Overcurrent Protective Device
208/60/3	31	40	40
230/60/3	29	40	40
460/60/3	15	20	20

SAMPLE TROUGH CONFIGURATIONS AND FEED METHODS

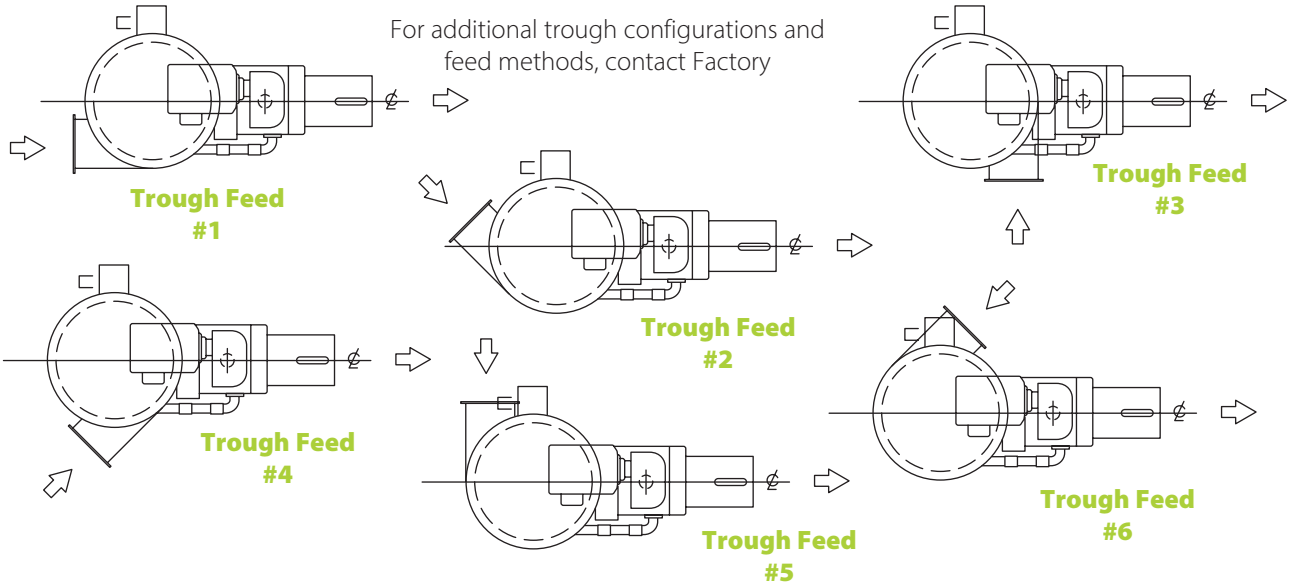

Feed Tray with Hood

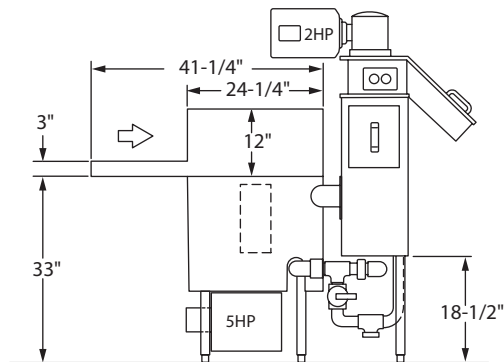
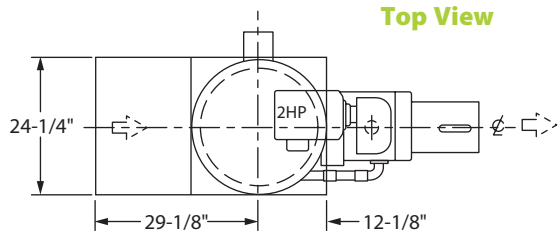

Front View

Under Table Feed Tray

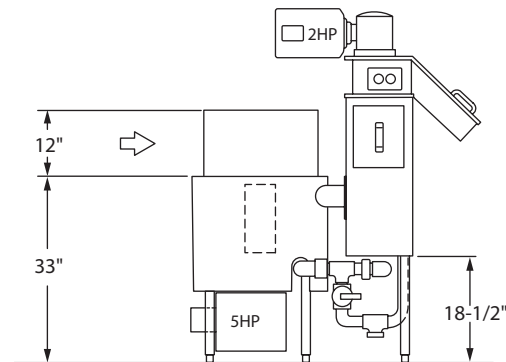
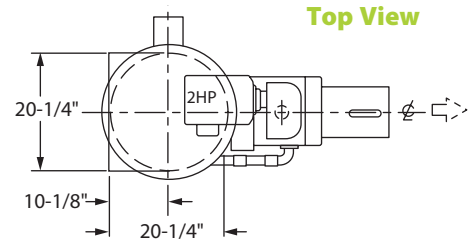

Front View

Due to an ongoing value analysis program at Bi-Line, specifications contained in this catalog are subject to change without notice.